

SCORREVOLI BREVETTATI / PATENTED

S LIDING S

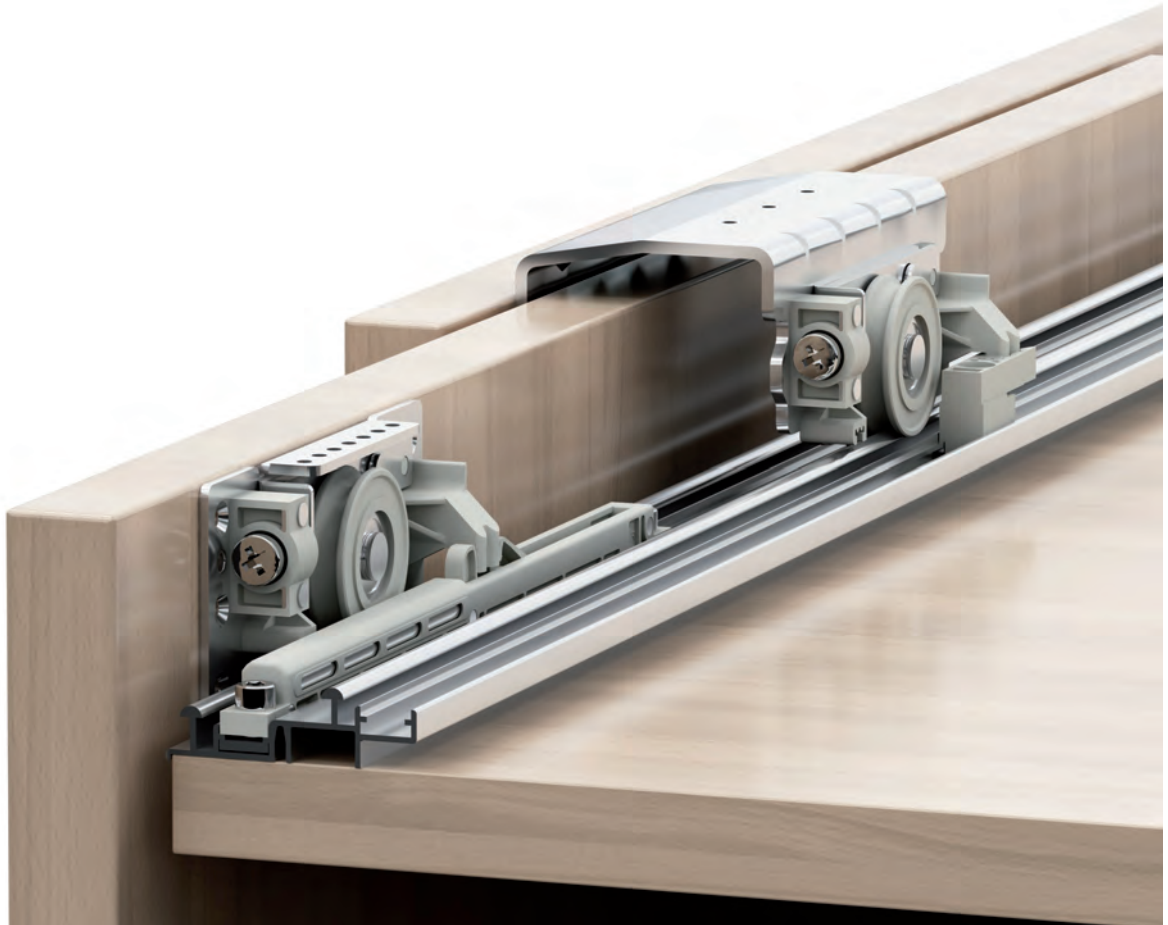

Sistema di scorrevoli regolabili per armadi con ante sovrapposte, dotato di fermi ammortizzati o fermi tradizionali a pinza.

Sliding, adjustable system of wardrobe doors with veneered panels, equipped with damped air stops or traditional clamp closing.

Système de rails coulissants réglables pour armoires avec vantaux parallèles, équipé d'amortisseurs de fin de course ou de fermetures traditionnelles à pinces.

Regulierbares Schiebetürsystem für Schränke mit überlappenden Türen, ausgestattet mit gedämpften Türschließern oder traditionellen Klemmtürschließern.

Sistema de correderas regulables para armarios con puertas superpuestas dotado de cerrojos amortiguados o cerrojos tradicionales tipo pinza.



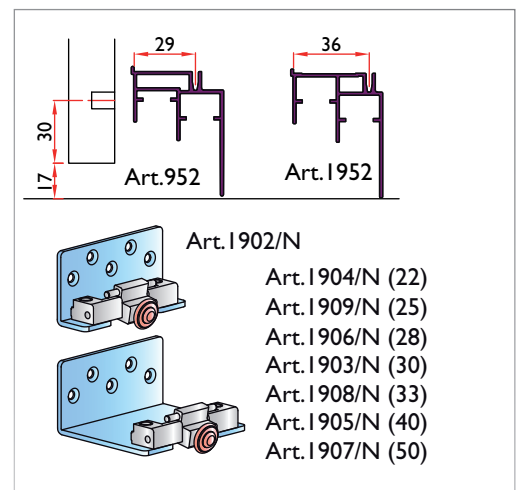
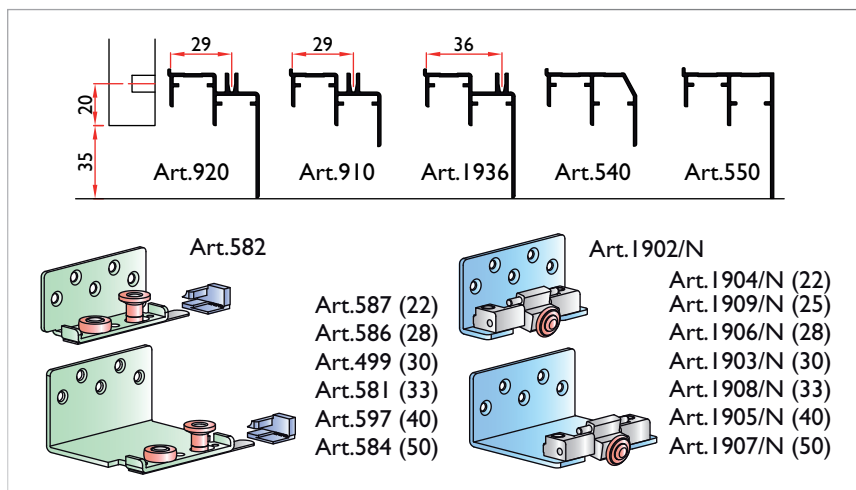
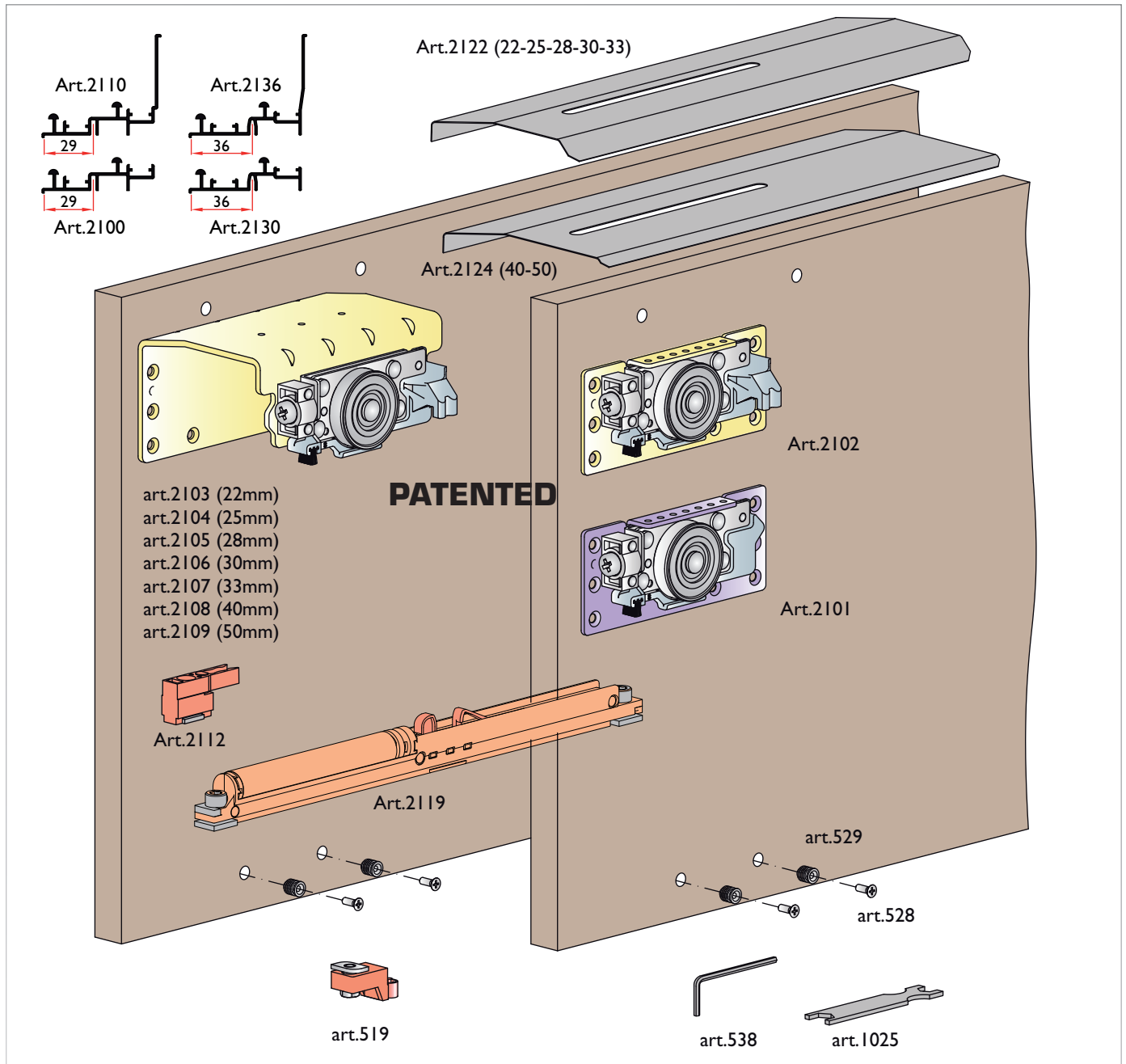

**Scorrevoli per ante**  
**spessore max mm. 22 - 80 kg**

Slides for door with maximum thickness of 22 mm - 80 kg  
 Coulisses pour portes de 22mm. D'epaisseur max. - 80 kg  
 Schlitten für türen max. Stärke mm. 22 - 80 kg  
 Elementos de deslizamiento para puertas con espesor max. De 22 mm. - 80 kg



**SCORREVOLE CON AMMORTIZZATORE**  
**SLIDING SYSTEM WITH SOFT CLOSING**

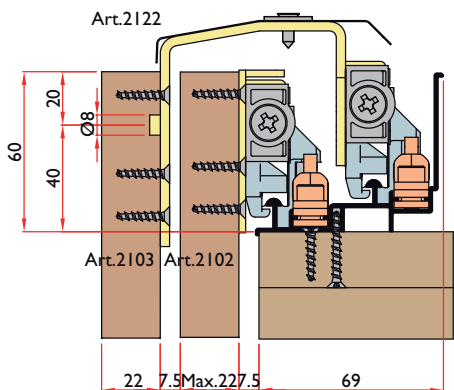

**SCORREVOLE CON FERMO A PINZA**  
**SLIDING SYSTEM WITH CLASSIC STOPPER**

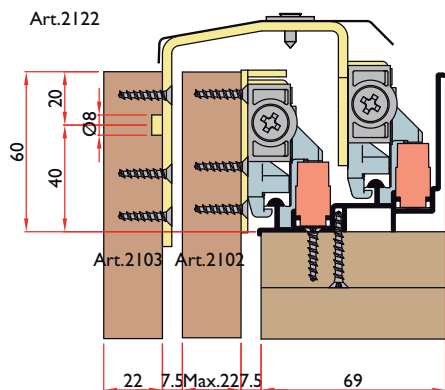

**35 mm - GUIDA MANUALE**  
**35 mm - MANUAL GUIDE**

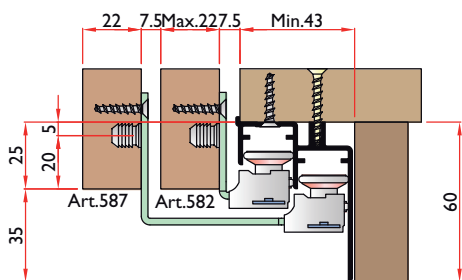

**35 mm - GUIDA A SCATTO**  
**35 mm - SNAP HOOK GUIDE**

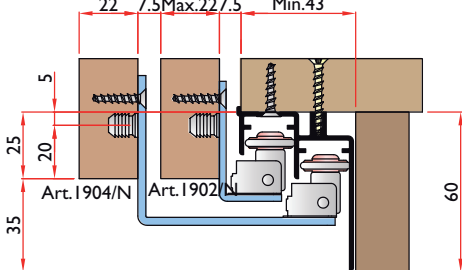

**17 mm - GUIDA A SCATTO**  
**17 mm - SNAP HOOK GUIDE**

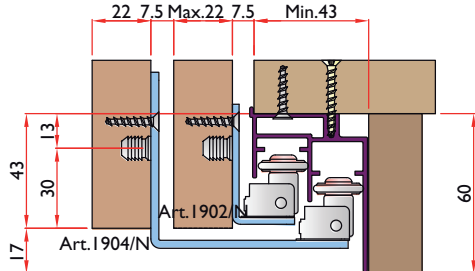

**OPTIONAL - COPERTURA**  
**OPTIONAL - COVER**

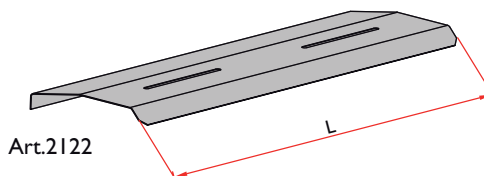

**BINARI IN ALLUMINIO SUPERIORI**  
**UPPER ALUMINIUM TRACKS**

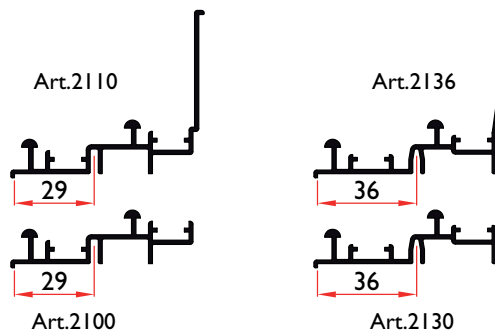

**BINARI IN ALLUMINIO INFERIORI**  
**LOWER ALUMINIUM TRACKS**

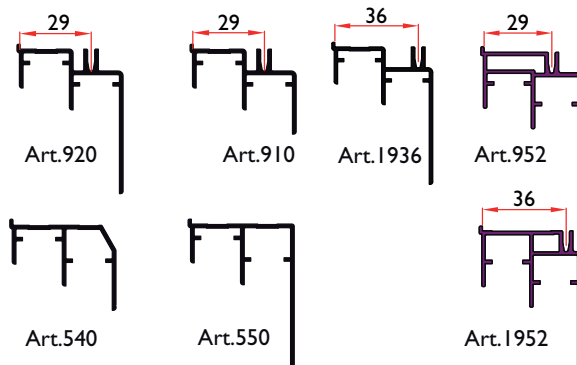

**Kit per ante spessore  
max mm. 22 - 80 kg**

Kit for door with maximum thickness of 22 mm - 80 kg  
 Kit pour portes de 22 mm. d'épaisseur max - 80 kg  
 Kit für türen max.stärke mm. 22 - 80 kg  
 Kit para puertas con espesor max de 22 mm - 80 kg



STAR

2 ANTE CON 4 AMMORTIZZATORI 2 DOORS WITH 4 SOFT CLOSING	<b>ART.2103/587/2119/2A</b>  Art.1025    n°8 Art.528 Art.538    n°4 Art.519    n°8 Art.529	 Art.2103	 Art.2102	 n 4 Art.2119  n.2 Art.582    n.2 Art.587
	<b>ART.2103/1904/2119/2A</b>  Art.1025    n°8 Art.528 Art.538    n°4 Art.519    n°8 Art.529	 Art.2103	 Art.2102	 n 4 Art.2119  n.2 Art.1902/N    n.2 Art.1904/N
3 ANTE CON 6 AMMORTIZZATORI 3 DOORS WITH 6 SOFT CLOSING	<b>ART.2103/587/2119/3A</b>  Art.1025    n°12 Art.528 Art.538    n°4 Art.519    n°12 Art.529	 Art.2103	 Art.2102	 n 6 Art.2119  n.4 Art.582    n.2 Art.587
	<b>ART.2103/1904/2119/3A</b>  Art.1025    n°12 Art.528 Art.538    n°4 Art.519    n°12 Art.529	 Art.2103	 Art.2102	 n 6 Art.2119  n.4 Art.1902/N    n.2 Art.1904/N
2 ANTE CON 4 FERMI A PINZA 2 DOORS WITH 4 CLASSIC STOPPER	<b>ART.2103/587/2112/2A</b>  Art.1025    n°8 Art.528 Art.538    n°4 Art.519    n°8 Art.529	 Art.2103	 Art.2102	 n 4 Art.2112  n.2 Art.582    n.2 Art.587
	<b>ART.2103/1904/2112/2A</b>  Art.1025    n°8 Art.528 Art.538    n°4 Art.519    n°8 Art.529	 Art.2103	 Art.2102	 n 4 Art.2112  n.2 Art.1902/N    n.2 Art.1904/N
3 ANTE CON 6 FERMI A PINZA 3 DOORS WITH 6 CLASSIC STOPPER	<b>ART.2103/587/2112/3A</b>  Art.1025    n°12 Art.528 Art.538    n°4 Art.519    n°12 Art.529	 Art.2103	 Art.2102	 n 6 Art.2112  n.4 Art.582    n.2 Art.587
	<b>ART.2103/1904/2112/3A</b>  Art.1025    n°12 Art.528 Art.538    n°4 Art.519    n°12 Art.529	 Art.2103	 Art.2102	 n 6 Art.2112  n.4 Art.1902/N    n.2 Art.1904/N



**Scorrevoli per ante spessore max mm. 25 - 80 kg**

Slides for door with maximum thickness of 25 mm - 80 kg  
 Coulisses pour portes de 25mm. D'épaisseur max. - 80 kg  
 Schlitten für türen max. Stärke mm. 25 - 80 kg  
 Elementos de deslizamiento para puertas con espesor max. De 25 mm. - 80 kg



**SCORREVOLE CON AMMORTIZZATORE**  
**SLIDING SYSTEM WITH SOFT CLOSING**

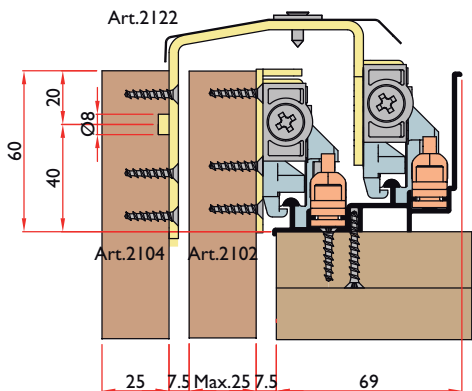

**SCORREVOLE CON FERMO A PINZA**  
**SLIDING SYSTEM WITH CLASSIC STOPPER**

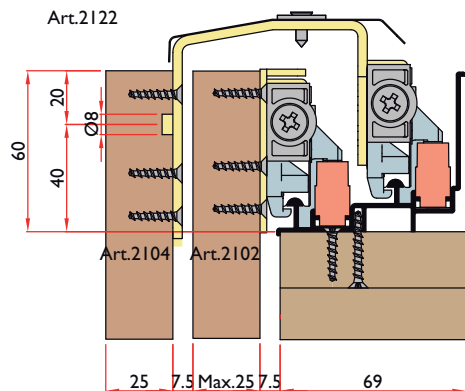

**35 mm - GUIDA A SCATTO**  
**35 mm - SNAP HOOK GUIDE**

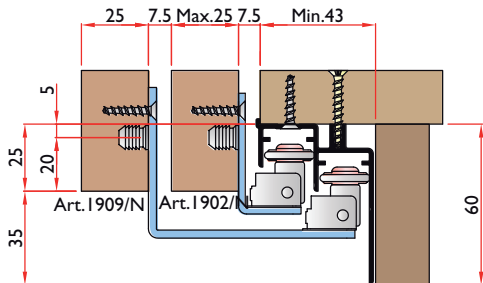

**17 mm - GUIDA A SCATTO**  
**17 mm - SNAP HOOK GUIDE**

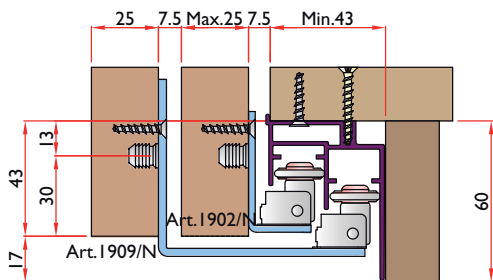

**OPTIONAL - COPERTURA**  
**OPTIONAL - COVER**

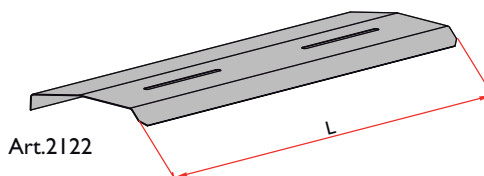

**BINARI IN ALLUMINIO SUPERIORI**  
**UPPER ALUMINIUM TRACKS**

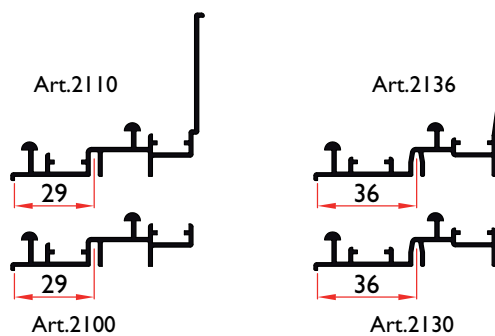

**BINARI IN ALLUMINIO INFERIORI**  
**LOWER ALUMINIUM TRACKS**

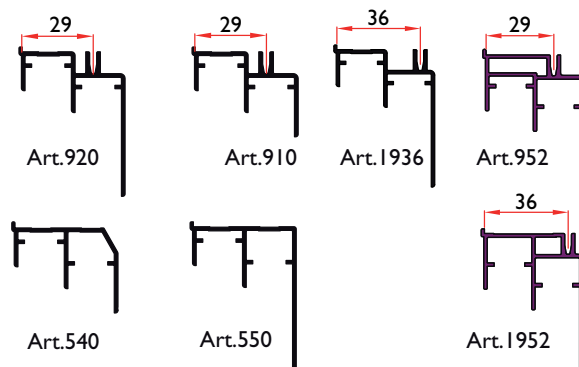

**Kit per ante spessore  
max mm. 25 - 80 kg**

Kit for door with maximum thickness of 25 mm - 80 kg  
 Kit pour portes de 25 mm. d'épaisseur max - 80 kg  
 Kit für türen max.starke mm. 25 - 80 kg  
 Kit para puertas con espesor max de 25 mm - 80 kg

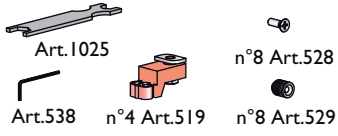
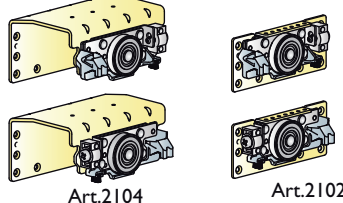
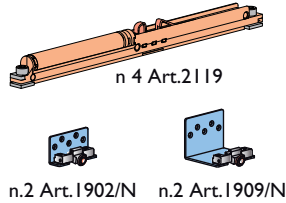
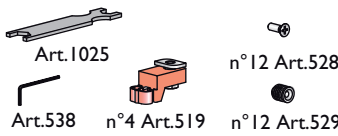
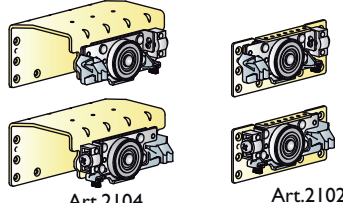
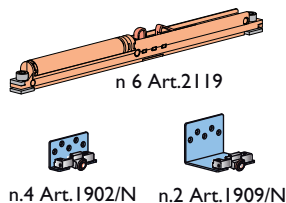
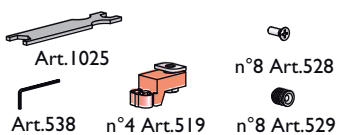
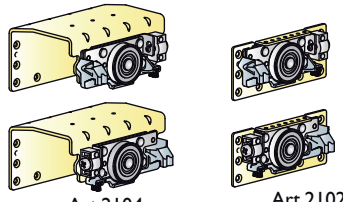
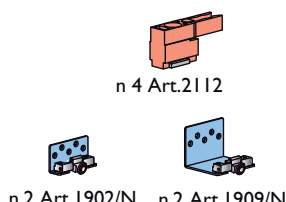
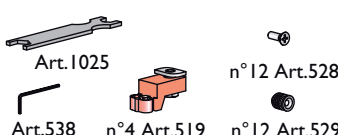
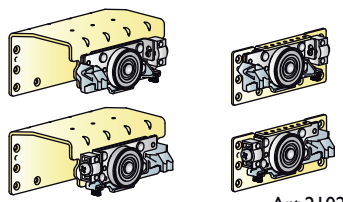
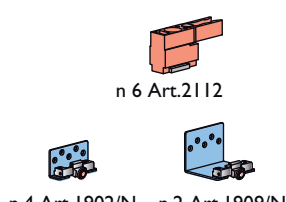

<p>2 ANTE CON 4 AMMORTIZZATORI 2 DOORS WITH 4 SOFT CLOSING</p>	<p><b>ART.2104/1909/2119/2A</b></p> 	 <p>Art.2104      Art.2102</p>	 <p>n 4 Art.2119 n.2 Art.1902/N    n.2 Art.1909/N</p>
<p>3 ANTE CON 6 AMMORTIZZATORI 3 DOORS WITH 6 SOFT CLOSING</p>	<p><b>ART.2104/1909/2119/3A</b></p> 	 <p>Art.2104      Art.2102</p>	 <p>Art.2101      n 6 Art.2119 n.4 Art.1902/N    n.2 Art.1909/N</p>
<p>2 ANTE CON 4 FERMI A PINZA 2 DOORS WITH 4 CLASSIC STOPPER</p>	<p><b>ART.2104/1909/2112/2A</b></p> 	 <p>Art.2104      Art.2102</p>	 <p>n 4 Art.2112 n.2 Art.1902/N    n.2 Art.1909/N</p>
<p>3 ANTE CON 6 FERMI A PINZA 3 DOORS WITH 6 CLASSIC STOPPER</p>	<p><b>ART.2104/1909/2112/3A</b></p> 	 <p>Art.2104      Art.2102</p>	 <p>Art.2101      n 6 Art.2112 n.4 Art.1902/N    n.2 Art.1909/N</p>

# Scorrevoli per ante spessore max mm. 28 - 80 kg



Slides for door with maximum thickness of 28 mm - 80 kg  
 Coulisses pour portes de 28mm. D'epaisseur max. - 80 kg  
 Schlitten für türen max. Stärke mm. 28 - 80 kg  
 Elementos de deslizamiento para puertas con espesor max. De 28 mm. - 80 kg

## SCORREVOLE CON AMMORTIZZATORE SLIDING SYSTEM WITH SOFT CLOSING

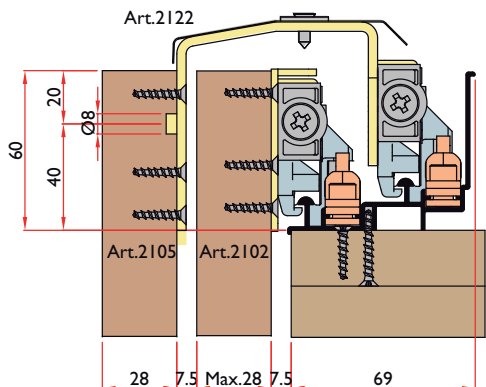

## SCORREVOLE CON FERMO A PINZA SLIDING SYSTEM WITH CLASSIC STOPPER

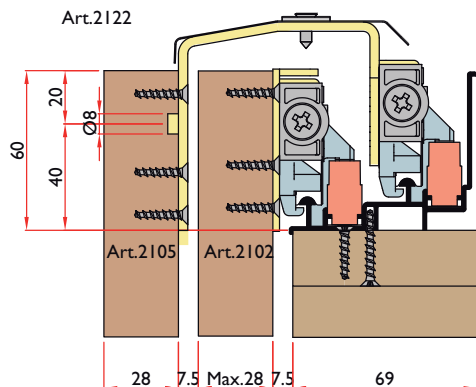

## 35 mm - GUIDA MANUALE 35 mm - MANUAL GUIDE

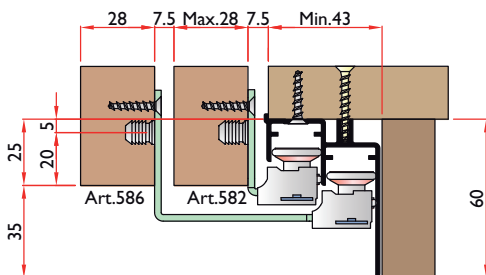

## 35 mm - GUIDA A SCATTO 35 mm - SNAP HOOK GUIDE

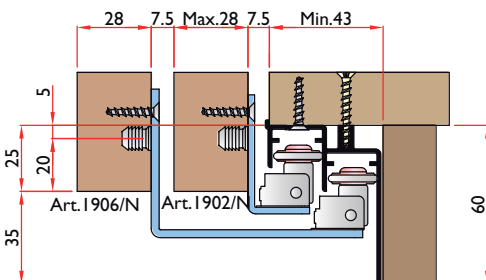

## 17 mm - GUIDA A SCATTO 17 mm - SNAP HOOK GUIDE

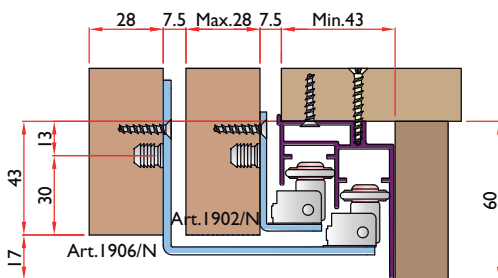

## OPTIONAL - COPERTURA OPTIONAL - COVER

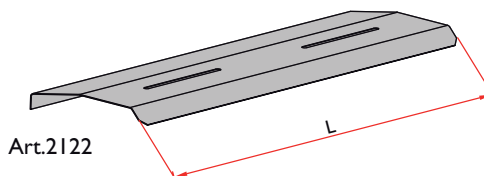

## BINARI IN ALLUMINIO SUPERIORI UPPER ALUMINIUM TRACKS

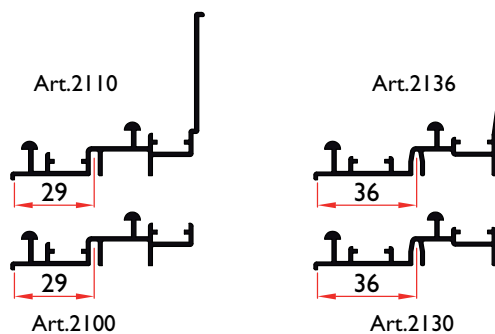

## BINARI IN ALLUMINIO INFERIORI LOWER ALUMINIUM TRACKS

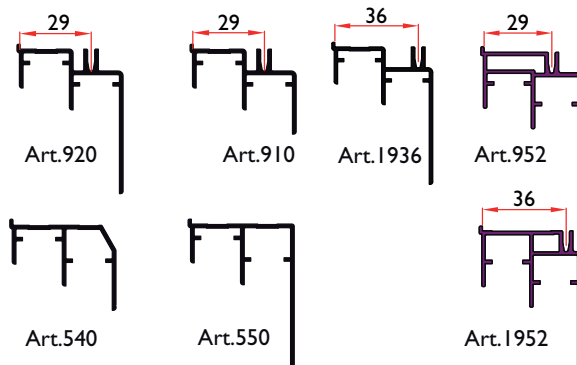

**Kit per ante spessore  
max mm. 28 - 80 kg**

Kit for door with maximum thickness of 28 mm - 80 kg  
 Kit pour portes de 28 mm. d'épaisseur max - 80 kg  
 Kit für türen max.stärke mm. 28 - 80 kg  
 Kit para puertas con espesor max de 28 mm - 80 kg



STAR

2 ANTE CON 4 AMMORTIZZATORI 2 DOORS WITH 4 SOFT CLOSING	<b>ART.2105/586/2119/2A</b>  
	<b>ART.2105/1906/2119/2A</b>  
3 ANTE CON 6 AMMORTIZZATORI 3 DOORS WITH 6 SOFT CLOSING	<b>ART.2105/586/2119/3A</b>  
	<b>ART.2105/1906/2119/3A</b>  
2 ANTE CON 4 FERMI A PINZA 2 DOORS WITH 4 CLASSIC STOPPER	<b>ART.2105/586/2112/2A</b>  
	<b>ART.2105/1906/2112/2A</b>  
3 ANTE CON 6 FERMI A PINZA 3 DOORS WITH 6 CLASSIC STOPPER	<b>ART.2105/586/2112/3A</b>  
	<b>ART.2105/1906/2112/3A</b>  



**Scorrevoli per ante**  
**spessore max mm. 30 - 80 kg**

Slides for door with maximum thickness of 30 mm - 80 kg  
 Coulisses pour portes de 30mm. D'épaisseur max. - 80 kg  
 Schlitten für türen max. Stärke mm. 30 - 80 kg  
 Elementos de deslizamiento para puertas con espesor max. De 30 mm. - 80 kg



**SCORREVOLE CON AMMORTIZZATORE**  
**SLIDING SYSTEM WITH SOFT CLOSING**

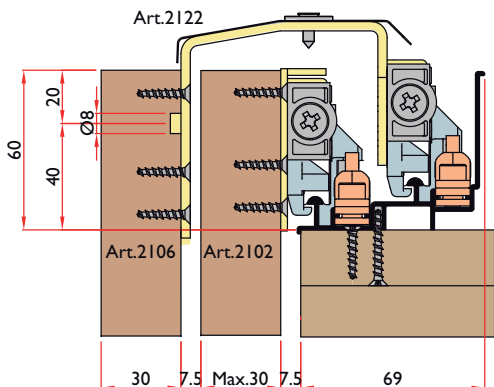

**SCORREVOLE CON FERMO A PINZA**  
**SLIDING SYSTEM WITH CLASSIC STOPPER**

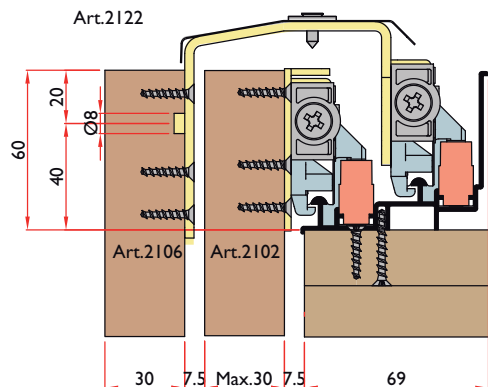

**35 mm - GUIDA MANUALE**  
**35 mm - MANUAL GUIDE**

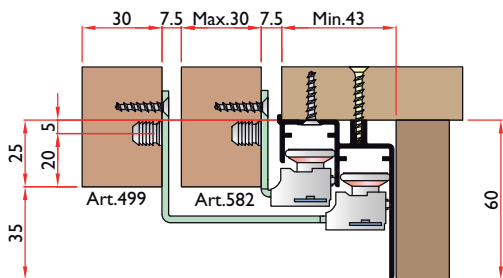

**35 mm - GUIDA A SCATTO**  
**35 mm - SNAP HOOK GUIDE**

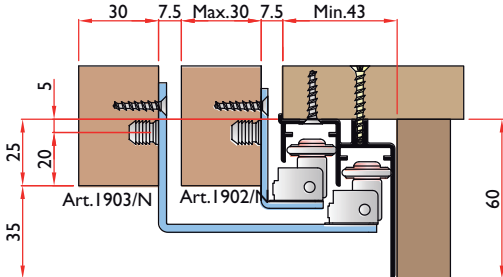

**17 mm - GUIDA A SCATTO**  
**17 mm - SNAP HOOK GUIDE**

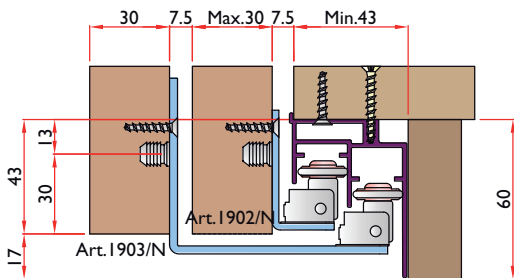

**OPTIONAL - COPERTURA**  
**OPTIONAL - COVER**

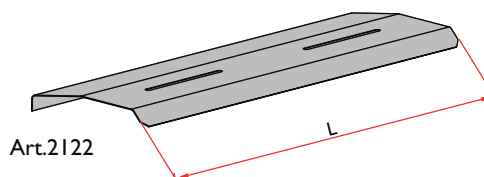

**BINARI IN ALLUMINIO SUPERIORI**  
**UPPER ALUMINIUM TRACKS**

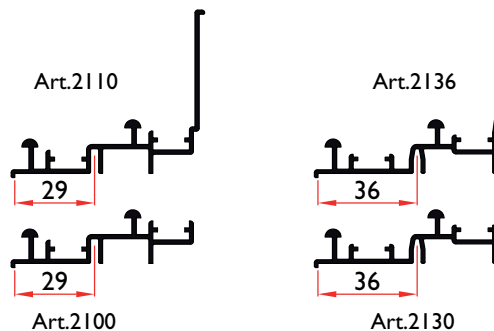

**BINARI IN ALLUMINIO INFERIORI**  
**LOWER ALUMINIUM TRACKS**

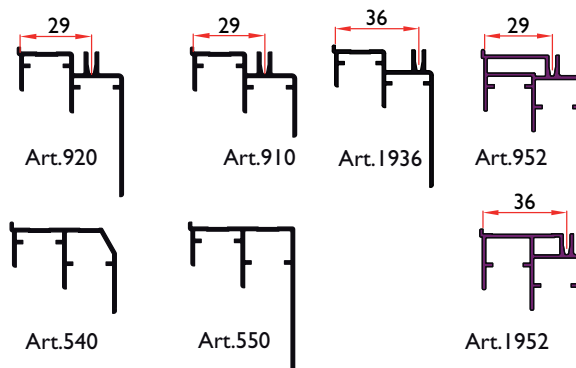

**Kit per ante spessore  
max mm. 30 - 80 kg**



STAR

Kit for door with maximum thickness of 30 mm - 80 kg  
 Kit pour portes de 30 mm. d'épaisseur max - 80 kg  
 Kit für türen max.stärke mm. 30 - 80 kg  
 Kit para puertas con espesor max de 30 mm - 80 kg

2 ANTE CON 4 AMMORTIZZATORI 2 DOORS WITH 4 SOFT CLOSING	<b>ART.2106/499/2119/2A</b>  
	<b>ART.2106/1903/2119/2A</b>  
3 ANTE CON 6 AMMORTIZZATORI 3 DOORS WITH 6 SOFT CLOSING	<b>ART.2106/499/2119/3A</b>  
	<b>ART.2106/1903/2119/3A</b>  
2 ANTE CON 4 FERMI A PINZA 2 DOORS WITH 4 CLASSIC STOPPER	<b>ART.2106/499/2112/2A</b>  
	<b>ART.2106/1903/2112/2A</b>  
3 ANTE CON 6 FERMI A PINZA 3 DOORS WITH 6 CLASSIC STOPPER	<b>ART.2106/499/2112/3A</b>  
	<b>ART.2106/1903/2112/3A</b>  

**Scorrevoli per ante spessore max mm. 33 - 80 kg**

Slides for door with maximum thickness of 33 mm - 80 kg  
 Coulisses pour portes de 33mm. D'epaisseur max. - 80 kg  
 Schlitten für türen max. Stärke mm. 33 - 80 kg  
 Elementos de deslizamiento para puertas con espesor max. De 33 mm. - 80 kg



**SCORREVOLE CON AMMORTIZZATORE**  
**SLIDING SYSTEM WITH SOFT CLOSING**

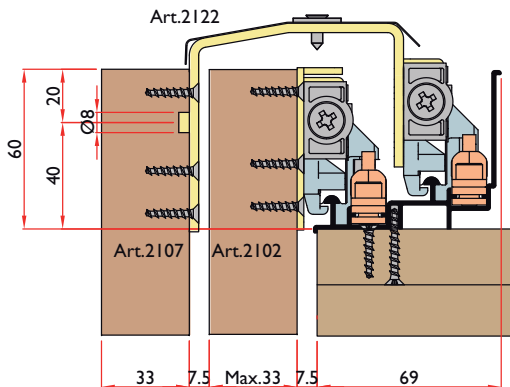

**SCORREVOLE CON FERMO A PINZA**  
**SLIDING SYSTEM WITH CLASSIC STOPPER**

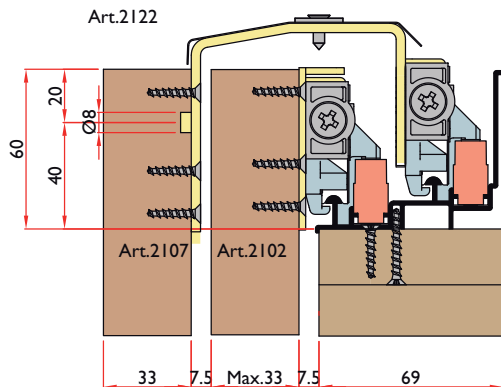

**35 mm - GUIDA MANUALE**  
**35 mm - MANUAL GUIDE**

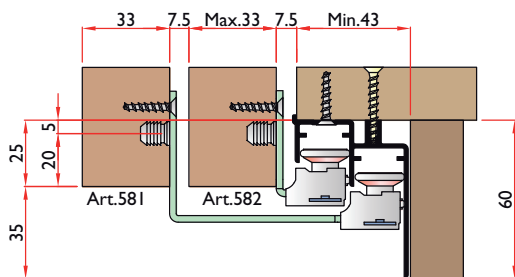

**35 mm - GUIDA A SCATTO**  
**35 mm - SNAP HOOK GUIDE**

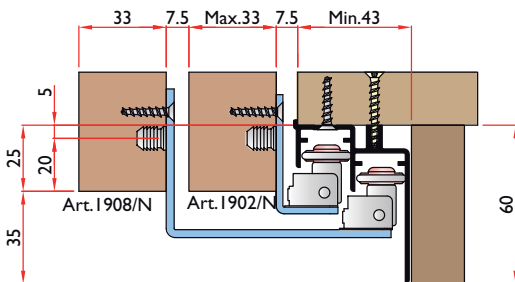

**17 mm - GUIDA A SCATTO**  
**17 mm - SNAP HOOK GUIDE**

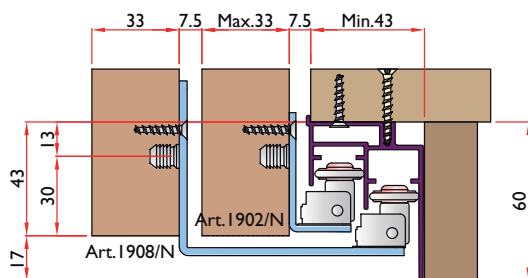

**OPTIONAL - COPERTURA**  
**OPTIONAL - COVER**

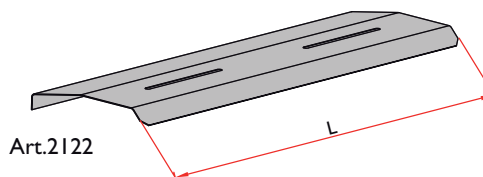

**BINARI IN ALLUMINIO SUPERIORI**  
**UPPER ALUMINIUM TRACKS**

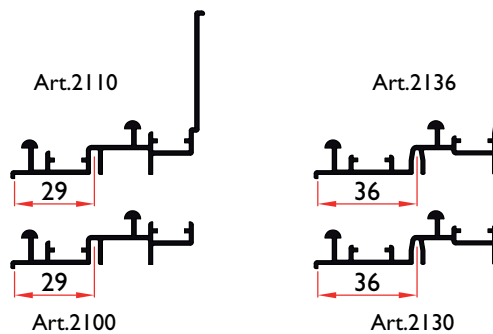

**BINARI IN ALLUMINIO INFERIORI**  
**LOWER ALUMINIUM TRACKS**

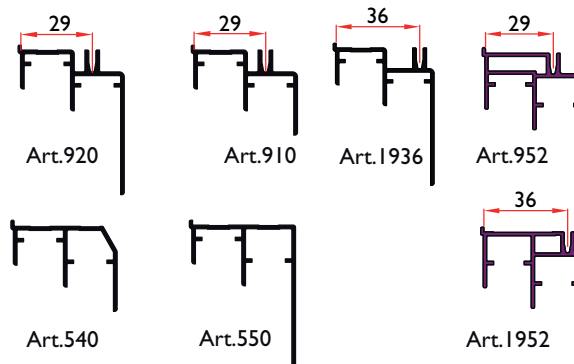

**Kit per ante spessore  
max mm. 33 - 80 kg**

Kit for door with maximum thickness of 33 mm - 80 kg  
 Kit pour portes de 33 mm. d'épaisseur max- 80 kg  
 Kit für türen max. starke mm. 33- 80 kg  
 Kit para puertas con espesor max de 33 mm- 80 kg



STAR

2 ANTE CON 4 AMMORTIZZATORI 2 DOORS WITH 4 SOFT CLOSING	<b>ART.2107/581/2119/2A</b>  Art.1025 Art.538 n°4 Art.519 n°8 Art.528 n°8 Art.529	 Art.2106	 Art.2102	 n.4 Art.2119 n.2 Art.582 n.2 Art.499
	<b>ART.2107/1908/2119/2A</b>  Art.1025 Art.538 n°4 Art.519 n°8 Art.528 n°8 Art.529	 Art.2106	 Art.2102	 n.4 Art.2119 n.2 Art.1902/N n.2 Art.1903/N
3 ANTE CON 6 AMMORTIZZATORI 3 DOORS WITH 6 SOFT CLOSING	<b>ART.2107/581/2119/3A</b>  Art.1025 Art.538 n°4 Art.519 n°12 Art.528 n°12 Art.529	 Art.2106	 Art.2102	 n.6 Art.2119 n.4 Art.582 n.2 Art.499
	<b>ART.2107/1908/2119/3A</b>  Art.1025 Art.538 n°4 Art.519 n°12 Art.528 n°12 Art.529	 Art.2106	 Art.2102	 n.6 Art.2119 n.4 Art.1902/N n.2 Art.1903/N
2 ANTE CON 4 FERMI A PINZA 2 DOORS WITH 4 CLASSIC STOPPER	<b>ART.2107/581/2112/2A</b>  Art.1025 Art.538 n°4 Art.519 n°8 Art.528 n°8 Art.529	 Art.2106	 Art.2102	 n.4 Art.2112 n.2 Art.582 n.2 Art.499
	<b>ART.2107/1908/2112/2A</b>  Art.1025 Art.538 n°4 Art.519 n°8 Art.528 n°8 Art.529	 Art.2106	 Art.2102	 n.4 Art.2112 n.2 Art.1902/N n.2 Art.1903/N
3 ANTE CON 6 FERMI A PINZA 3 DOORS WITH 6 CLASSIC STOPPER	<b>ART.2107/581/2112/3A</b>  Art.1025 Art.538 n°4 Art.519 n°12 Art.528 n°12 Art.529	 Art.2106	 Art.2102	 n.6 Art.2112 n.4 Art.582 n.2 Art.499
	<b>ART.2107/1908/2112/3A</b>  Art.1025 Art.538 n°4 Art.519 n°12 Art.528 n°12 Art.529	 Art.2106	 Art.2102	 n.6 Art.2112 n.4 Art.1902/N n.2 Art.1903/N



# Scorrevoli per ante spessore max mm. 40 - 70 kg

Slides for door with maximum thickness of 40 mm - 70 kg  
 Coulisses pour portes de 40mm. D'épaisseur max. - 70 kg  
 Schlitten für türen max. Stärke mm. 40 - 70 kg  
 Elementos de deslizamiento para puertas con espesor max. De 40 mm. - 70 kg



## SCORREVOLE CON AMMORTIZZATORE SLIDING SYSTEM WITH SOFT CLOSING

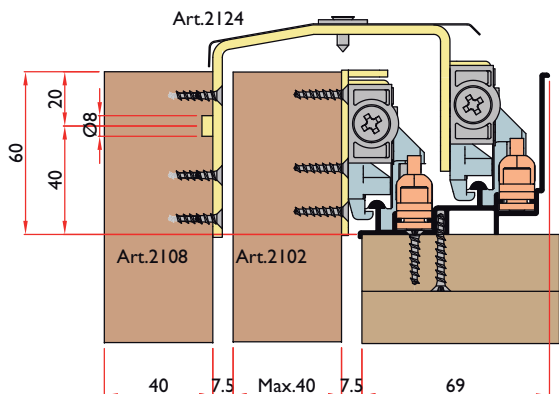

## SCORREVOLE CON FERMO A PINZA SLIDING SYSTEM WITH CLASSIC STOPPER

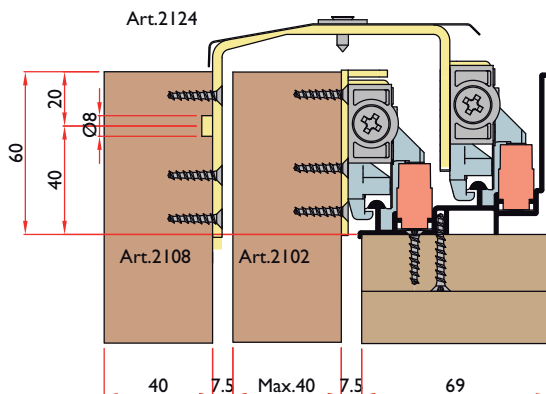

## 35 mm - GUIDA MANUALE 35 mm - MANUAL GUIDE

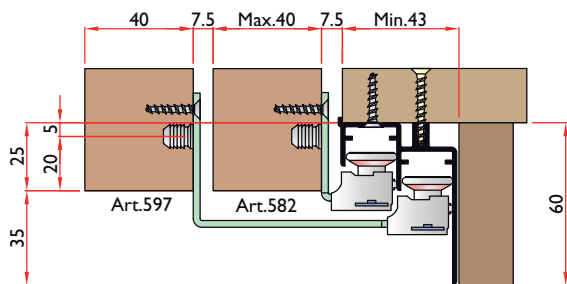

## 35 mm - GUIDA A SCATTO 35 mm - SNAP HOOK GUIDE

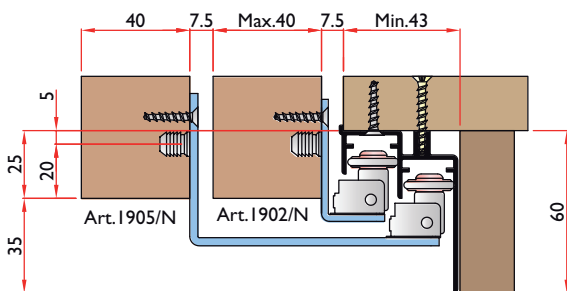

## 17 mm - GUIDA A SCATTO 17 mm - SNAP HOOK GUIDE

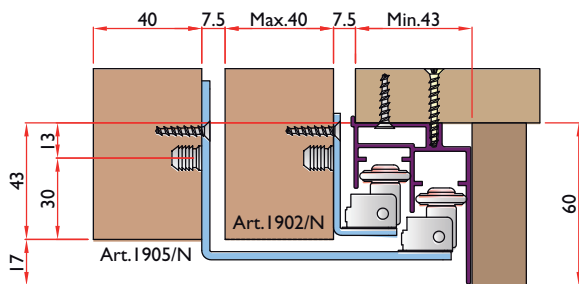

## OPTIONAL - COPERTURA OPTIONAL - COVER

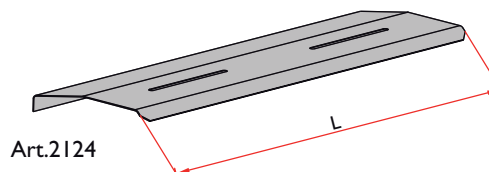

## BINARI IN ALLUMINIO SUPERIORI UPPER ALUMINIUM TRACKS

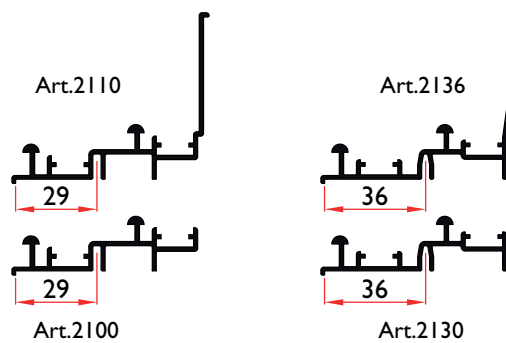

## BINARI IN ALLUMINIO INFERIORI LOWER ALUMINIUM TRACKS

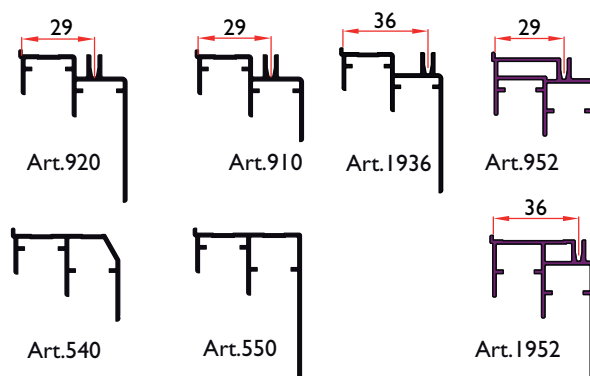

**Kit per ante spessore  
max mm. 40 - 70 kg**

Kit for door with maximum thickness of 40 mm - 70 kg  
 Kit pour portes de 40 mm. d'épaisseur max- 70 kg  
 Kit für türen max.stärke mm. 40 - 70 kg  
 Kit para puertas con espesor max de 40 mm - 70 kg



STAR

2 ANTE CON 4 AMMORTIZZATORI 2 DOORS WITH 4 SOFT CLOSING	<b>ART.2108/597/2119/2A</b>  
	<b>ART.2108/1905/2119/2A</b>  
3 ANTE CON 6 AMMORTIZZATORI 3 DOORS WITH 6 SOFT CLOSING	<b>ART.2108/597/2119/3A</b>  
	<b>ART.2108/1905/2119/3A</b>  
2 ANTE CON 4 FERMI A PINZA 2 DOORS WITH 4 CLASSIC STOPPER	<b>ART.2108/597/2112/2A</b>  
	<b>ART.2108/1905/2112/2A</b>  
3 ANTE CON 6 FERMI A PINZA 3 DOORS WITH 6 CLASSIC STOPPER	<b>ART.2108/597/2112/3A</b>  
	<b>ART.2108/1905/2112/3A</b>  

# Scorrevoli per ante spessore max mm. 50 - 60 kg

Slides for door with maximum thickness of 50 mm - 60 kg  
 Coulisses pour portes de 50mm. D'epaisseur max. - 60 kg  
 Schlitten für türen max. Stärke mm. 50 - 60 kg  
 Elementos de deslizamiento para puertas con espesor max. De 50 mm. - 60 kg



## SCORREVOLE CON AMMORTIZZATORE SLIDING SYSTEM WITH SOFT CLOSING

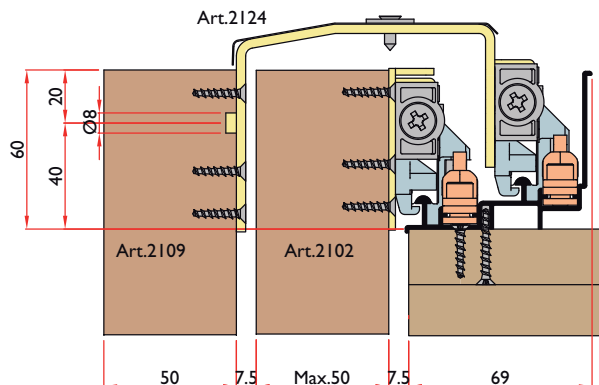

## SCORREVOLE CON FERMO A PINZA SLIDING SYSTEM WITH CLASSIC STOPPER

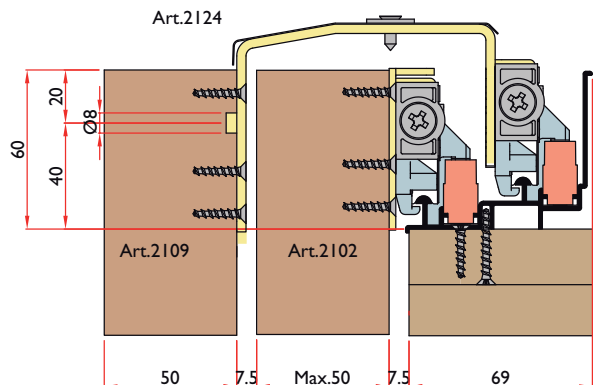

## 35 mm - GUIDA MANUALE 35 mm - MANUAL GUIDE

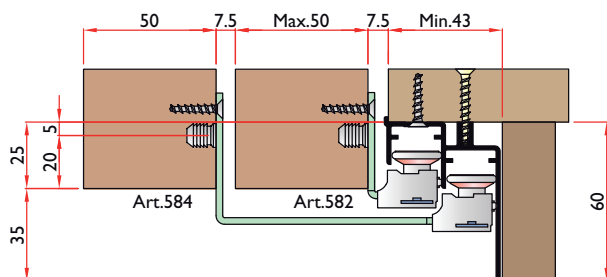

## 35 mm - GUIDA A SCATTO 35 mm - SNAP HOOK GUIDE

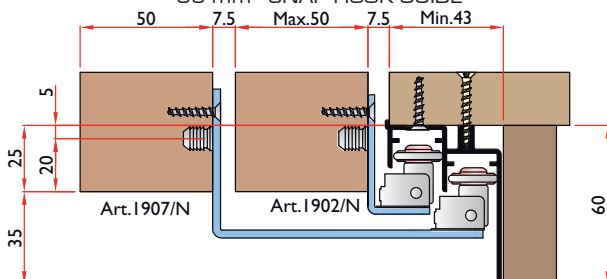

## 17 mm - GUIDA A SCATTO 17 mm - SNAP HOOK GUIDE

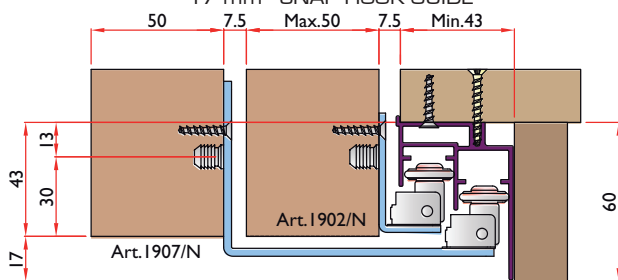

## OPTIONAL - COPERTURA OPTIONAL - COVER

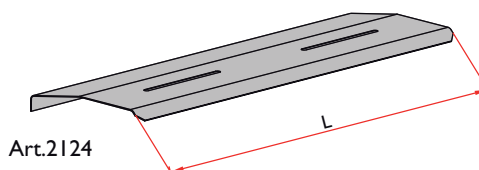

## BINARI IN ALLUMINIO SUPERIORI UPPER ALUMINIUM TRACKS

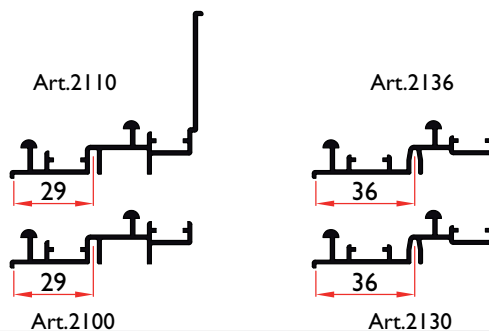

## BINARI IN ALLUMINIO INFERIORI LOWER ALUMINIUM TRACKS

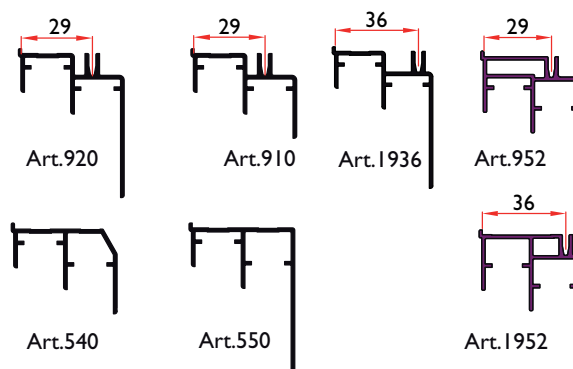

**Kit per ante spessore  
max mm. 50 - 60 kg**

Kit for door with maximum thickness of 40 mm - 60 kg  
 Kit pour portes de 40 mm. d'épaisseur max- 60 kg  
 Kit für türen max.starke mm. 40 - 60 kg  
 Kit para puertas con espesor max de 40 mm - 60 kg



STAR

2 ANTE CON 4 AMMORTIZZATORI 2 DOORS WITH 4 SOFT CLOSING	<b>ART.2109/584/2119/2A</b>  Art.1025    n°8 Art.528 Art.538    n°4 Art.519    n°8 Art.529	 Art.2109	 Art.2102	 n.4 Art.2119 n.2 Art.582    n.2 Art.584
	<b>ART.2109/1907/2119/2A</b>  Art.1025    n°8 Art.528 Art.538    n°4 Art.519    n°8 Art.529	 Art.2109	 Art.2102	 n.4 Art.2119 n.2 Art.1902/N    n.2 Art.1907/N
3 ANTE CON 6 AMMORTIZZATORI 3 DOORS WITH 6 SOFT CLOSING	<b>ART.2109/584/2119/3A</b>  Art.1025    n°12 Art.528 Art.538    n°4 Art.519    n°12 Art.529	 Art.2109	 Art.2102	 n.6 Art.2119 n.4 Art.582    n.2 Art.584
	<b>ART.2109/1907/2119/3A</b>  Art.1025    n°12 Art.528 Art.538    n°4 Art.519    n°12 Art.529	 Art.2109	 Art.2102	 n.6 Art.2119 n.4 Art.1902/N    n.2 Art.1907/N
2 ANTE CON 4 FERMI A PINZA 2 DOORS WITH 4 CLASSIC STOPPER	<b>ART.2109/584/2112/2A</b>  Art.1025    n°8 Art.528 Art.538    n°4 Art.519    n°8 Art.529	 Art.2109	 Art.2102	 n.4 Art.2112 n.2 Art.582    n.2 Art.584
	<b>ART.2109/1907/2112/2A</b>  Art.1025    n°8 Art.528 Art.538    n°4 Art.519    n°8 Art.529	 Art.2109	 Art.2102	 n.4 Art.2112 n.2 Art.1902/N    n.2 Art.1907/N
3 ANTE CON 6 FERMI A PINZA 3 DOORS WITH 6 CLASSIC STOPPER	<b>ART.2109/584/2112/3A</b>  Art.1025    n°12 Art.528 Art.538    n°4 Art.519    n°12 Art.529	 Art.2109	 Art.2102	 n.6 Art.2112 n.4 Art.582    n.2 Art.584
	<b>ART.2109/1907/2112/3A</b>  Art.1025    n°12 Art.528 Art.538    n°4 Art.519    n°12 Art.529	 Art.2109	 Art.2102	 n.6 Art.2112 n.4 Art.1902/N    n.2 Art.1907/N



Armadio a 2 ante con 4 fermi a pinza in apertura e in chiusura  
Wardrobe with 2 doors, 4 classic stopper for opening and closing

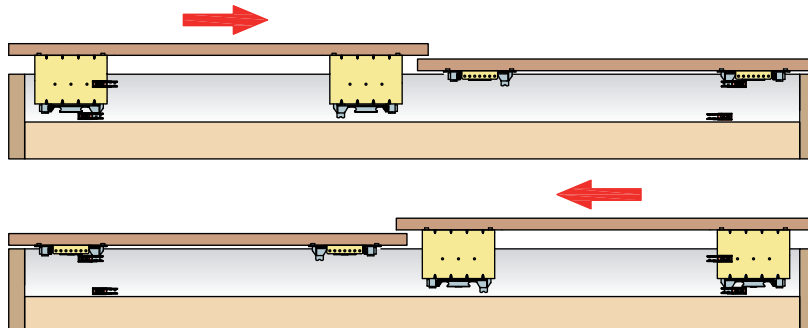

Armadio a 3 ante con 6 fermi a pinza in apertura e in chiusura  
Wardrobe with 3 doors, 6 classic stopper for opening and closing

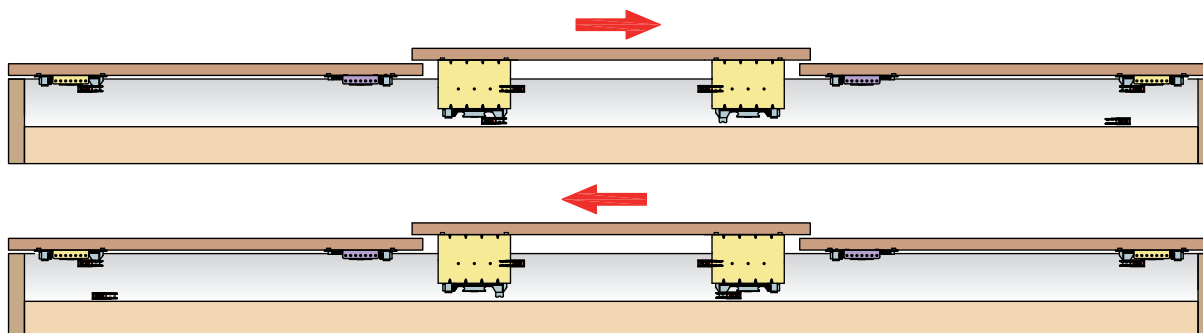

Armadio a 2 ante con 4 fermi ammortizzati in apertura e in chiusura  
Wardrobe with 2 doors, 4 soft closing for opening and closing

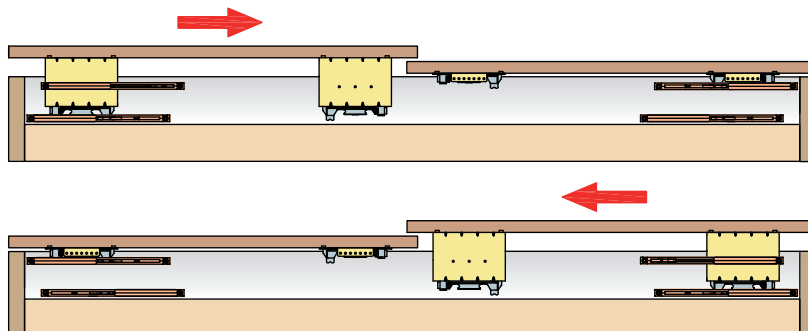

Armadio a 3 ante con 6 fermi ammortizzati in apertura e in chiusura  
Wardrobe with 3 doors, 6 soft closing for opening and closing

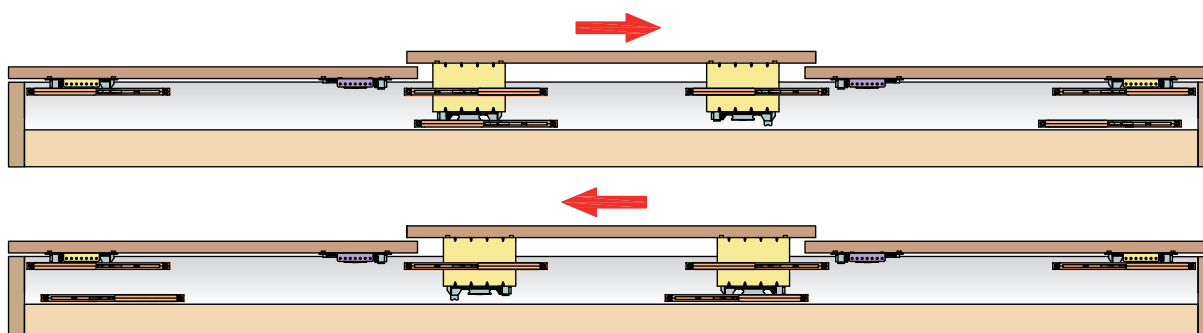

Armadio a 2 ante con 2 fermi ammortizzati in chiusura e fermi a pinza in apertura  
Wardrobe with 2 doors, 2 soft closing for closing and classic stopper for opening

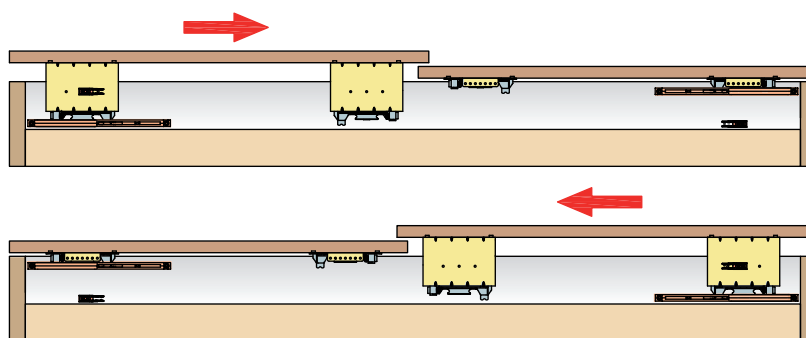

Armadio a 3 ante con fermi ammortizzati in chiusura, e fermi a pinza in apertura  
Wardrobe with 3 doors, soft closing for closing and classic stopper for opening

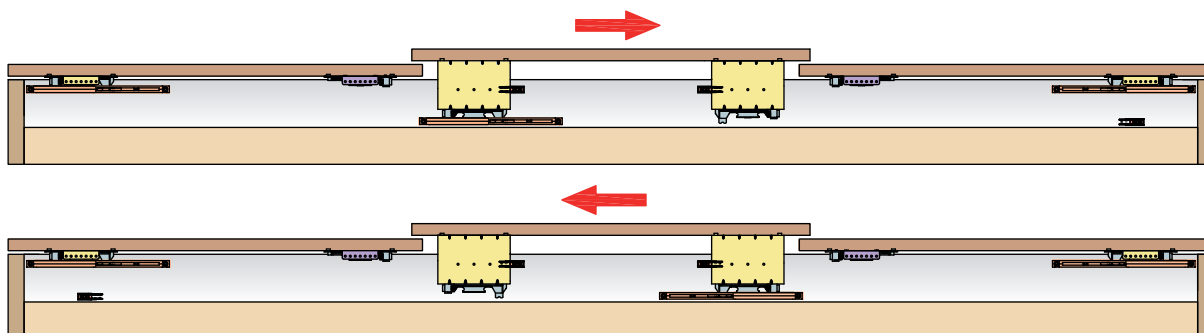

Armadio 3 ante con: ante interne con fermo ammortizzato in chiusura e fermi a pinza apertura;  
anta esterna ammortizzata in apertura e chiusura.  
3 doors Wardrobe with: internal doors with soft closing for closing and classic stopper for opening.  
External door with soft closing for opening and closing.

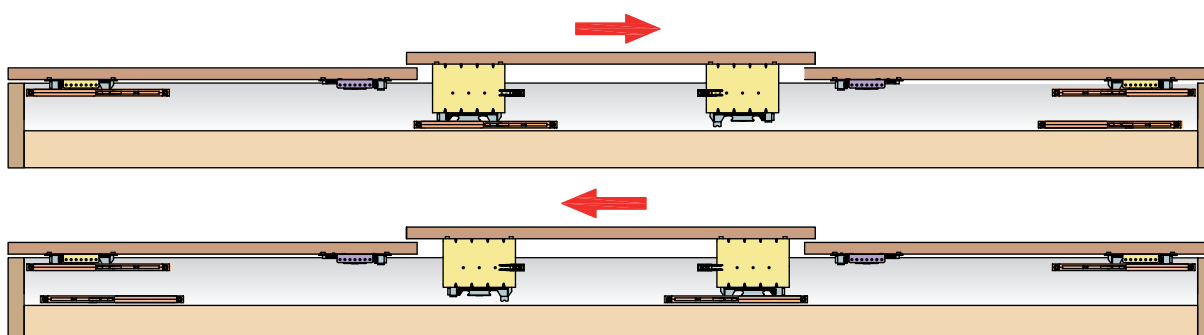

**SISTEMA DI FISSAGGIO CON BINARI FORATI**  
**CLAMPING SYSTEM WITH PUNCHED TRACKS**

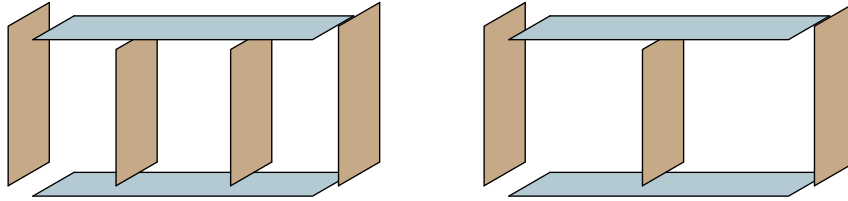

**BINARI SUPERIORI**  
**UPPER TRACK**

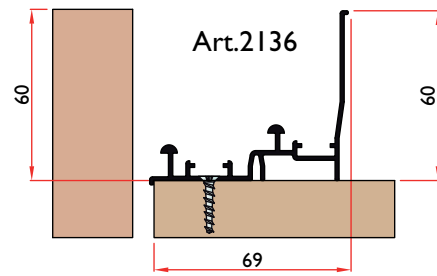
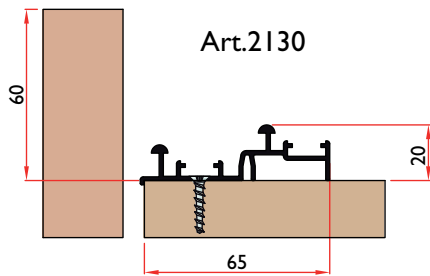
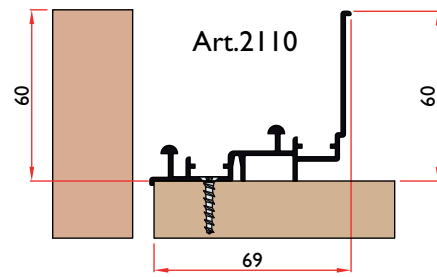
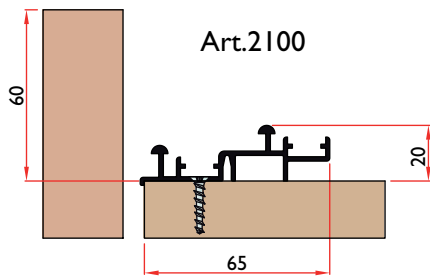

**BINARI INFERIORI. SPAZIO 35MM DA TERRA**  
**LOWER TRACKS. SPACED 35MM FROM THE GROUND**

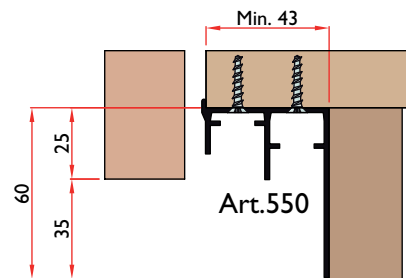
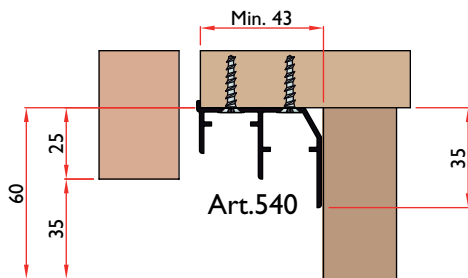

**BINARI INFERIORI. SPAZIO 17MM DA TERRA**  
**LOWER TRACKS. SPACED 17MM FROM THE GROUND**

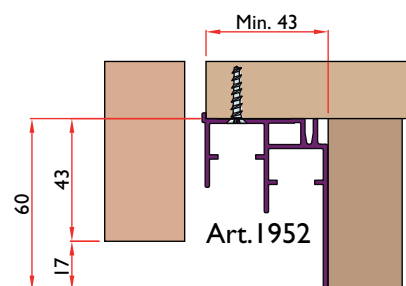
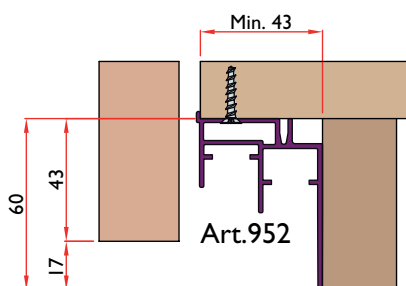

VITE Ø3,9x25  
SCREW Ø3,9x25

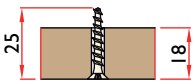

VITE Ø3,9x25  
SCREW Ø3,9x25

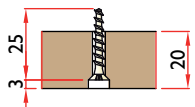

VITE Ø4,0x30  
SCREW Ø4,0x30

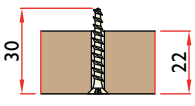

VITE Ø3,9x32  
SCREW Ø3,9x32

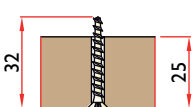

VITE Ø4,0x35  
SCREW Ø4,0x35

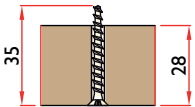

VITE Ø3,9x38  
SCREW Ø3,9x38

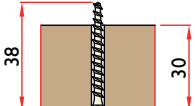

SISTEMA DI FISSAGGIO BINARI PER MOBILI COMPONIBILI  
CLAMPING SYSTEM WITH TRACKS FOR MODULAR FURNITURE

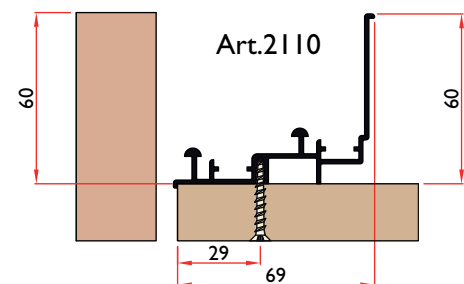
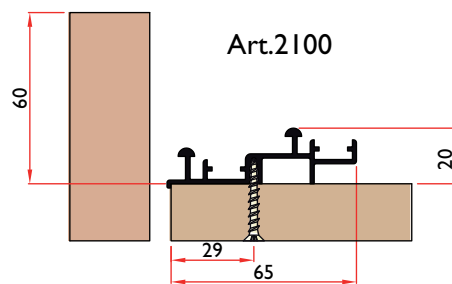
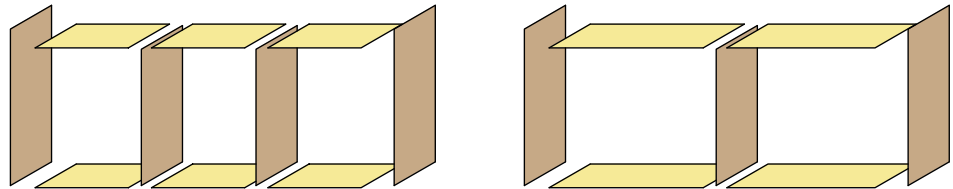

BINARI SUPERIORI  
UPPER TRACK

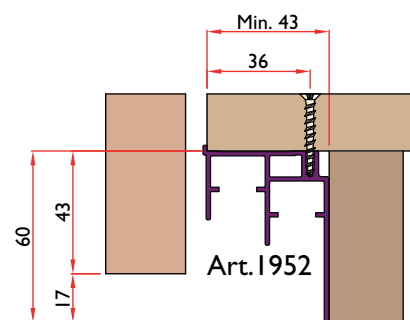
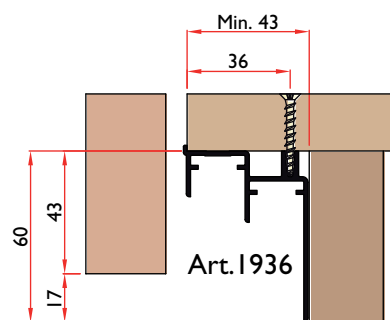
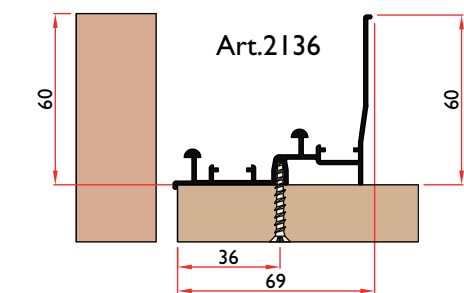
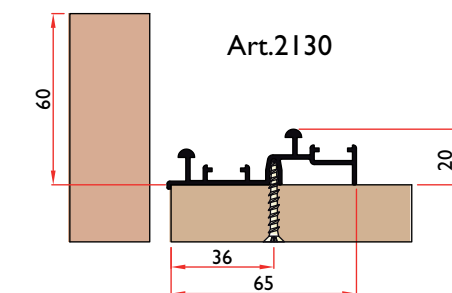

BINARI INFERIORI. SPAZIO 35MM DA TERRA  
LOWER TRACKS. SPACED 35MM FROM THE GROUND

BINARI INFERIORI. SPAZIO 17MM DA TERRA  
LOWER TRACKS. SPACED 17MM FROM THE GROUND

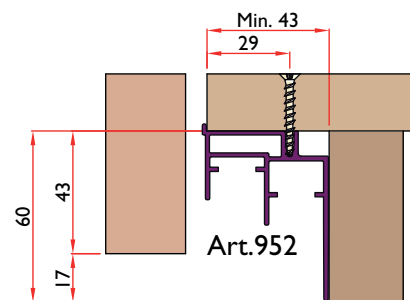
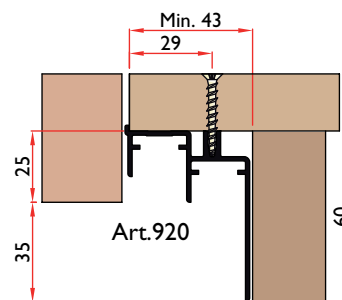
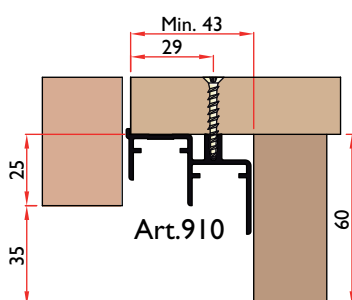



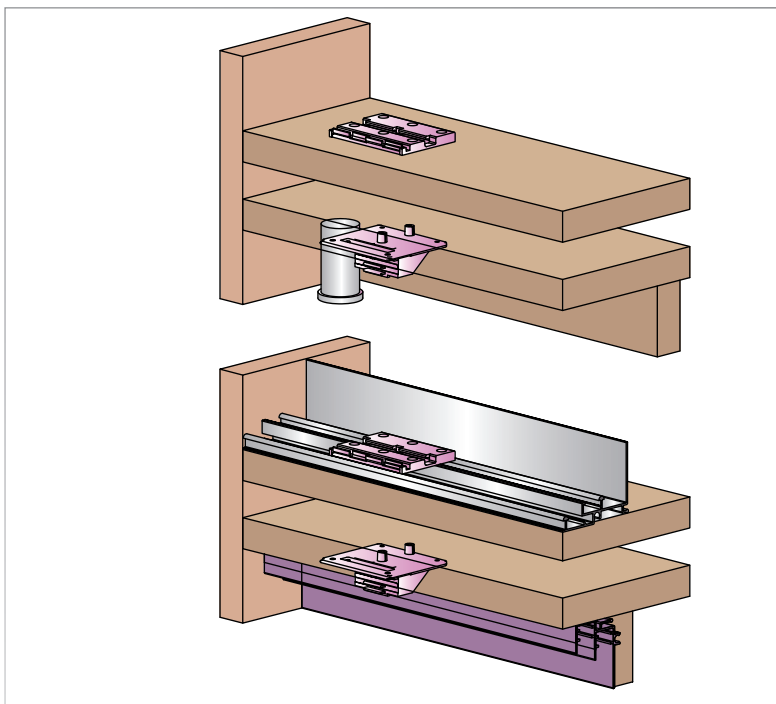
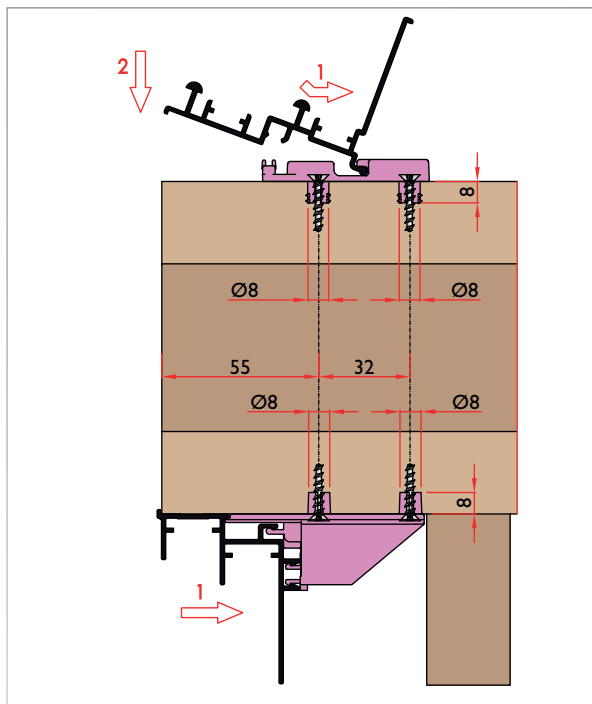
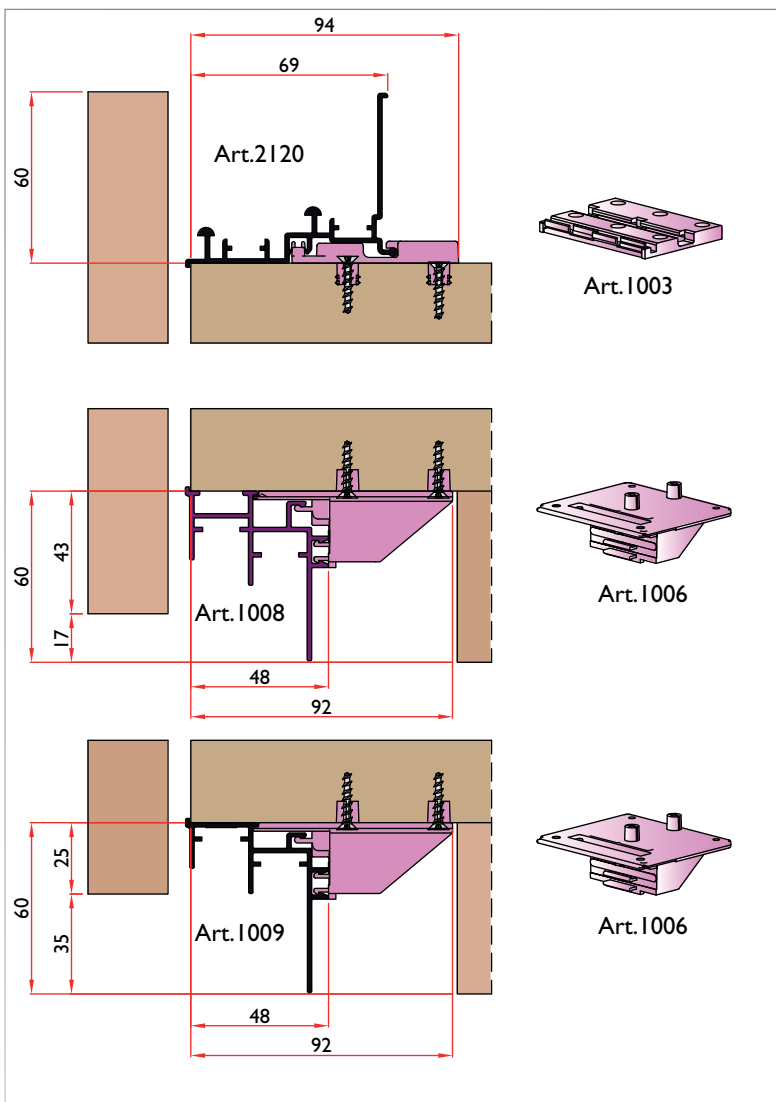
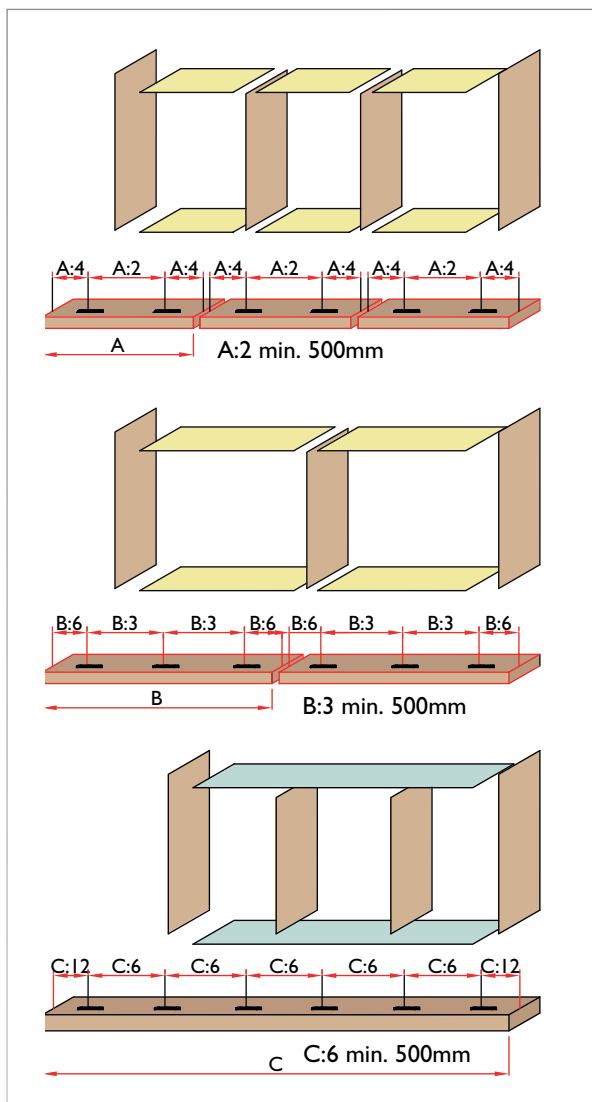

FERMO AMMORTIZZATO  
SOFT CLOSING

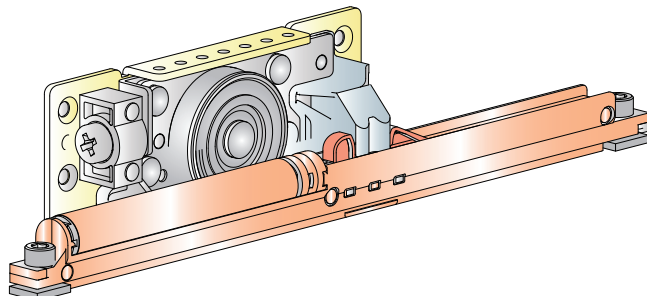

FERMO A PINZA  
CLASSIC STOPPER

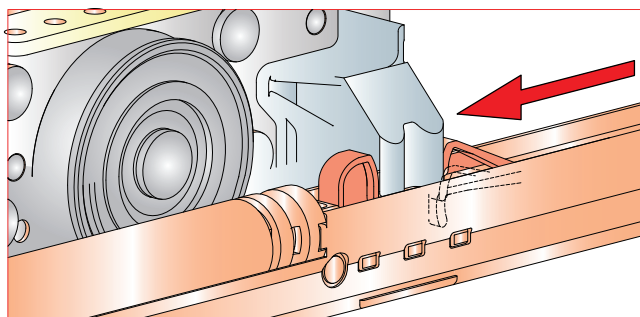
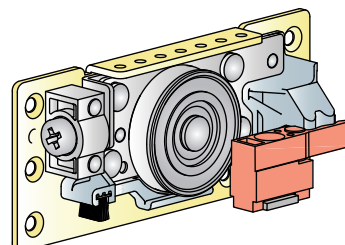

L'AMMORTIZZATORE SI CARICA AUTOMATICAMENTE  
AUTOMATICALLY LOADING OF SOFT CLOSING SYSTEM

SISTEMA DI ANTISGANCIAMENTO BREVETTATO  
PATENTED ANTI-UNHOOKING SYSTEM

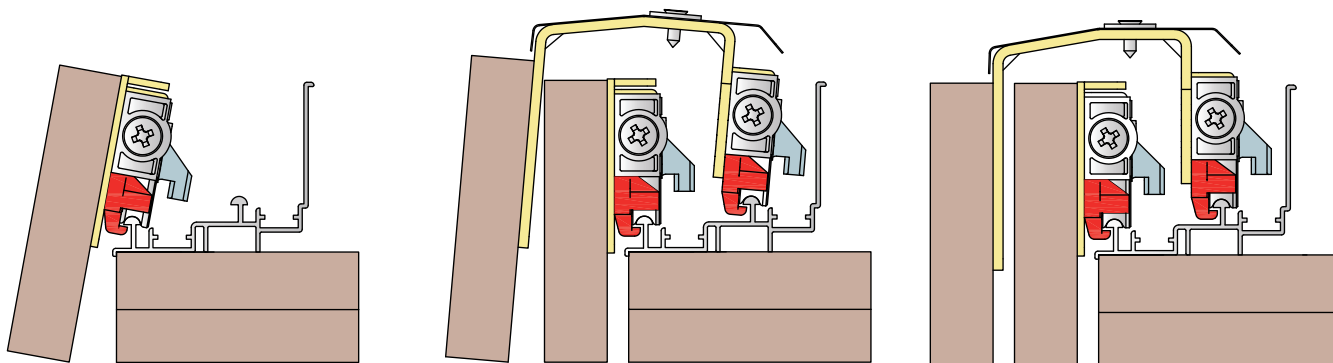

DISTANZA SPAZZOLINO  
BRUSH DISTANCE

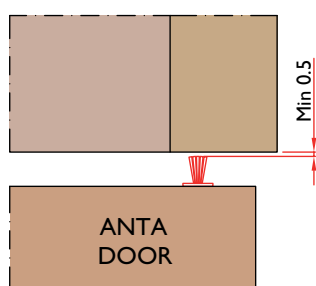

OPTIONAL SPAZZOLINO PARAPOLVERE PER LA PULIZIA DEI BINARI  
ANTI DUST BRUSH FOR TRACK CLEANING

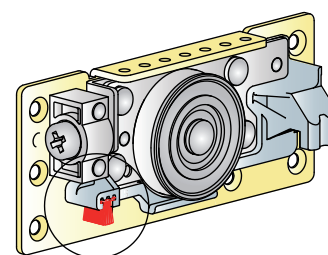
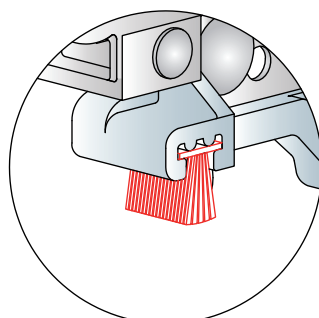

S = SORMONTO ANTA SU FIANCO  
 S = OVERLAP SIDE DOOR

